



HOGLUND BUS COMPANY
Your Fleet Solutions Partner

INSIDE THIS ISSUE:

- New & Used Inventory
- Parts Specials
- Service Information
- Service Special

School Bus Sales Team

Marc Steele (Northern)

C: 641.512.3854
 E: marcsteele@hoglundbus.com

Brian Glenney (Central)

C: 641.751.4365
 E: brianglenney@hoglundbus.com

Danny Thede (Southern)

C: 641.750.6428
 E: danny.thede@hoglundbus.com

Parts Sales

Al Lucas

C: 641.750.8332
 E: al.lucas@hoglundbus.com

DIRECT LINES:

Sales: 800.866.3105

Parts: 800.866.3104

Service: 877.752.4733

Tech Line: 763.271.2982



www.hoglundbus.com

SEPTEMBER 2017

— **School Bus Flyer** —

Welcome **Brian Watley** to the Hoglund Bus Team!



Brian has accepted the role of Sales Manager for both the School & Commercial Bus Teams. He is relocating from the Kansas City area and has been in the bus industry for many years. Please welcome him to Hoglund!

D: 763.271.8750 • C: 612.940.3477
 E: brian.watley@hoglundbus.com

OnCommand

OnCommand™ Connection is the industry's first and only open architecture remote diagnostic system for fleets of all makes and models of vehicles. Use OnCommand™ Connection to proactively identify potential problems, improve vehicle uptime, control maintenance and lower repair costs.

Features & Benefits

- Reduce** en-route events by proactively scheduling maintenance and repair
- Map** tools that plot truck locations, nearest dealers, hotels and local towing providers
- Generate** real-time comprehensive vehicle health reports
- Understand** fault codes quickly and easily with descriptions in plain English
- Gain** more insight with fault code action plans that provide severity information & recommend solutions

REPAIR-CONNECT.NET

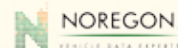

TRADE SHOWS

11/4 - 11/7 - NAPT, National Association for Pupil Transportation, Greater Columbus Convention Center, Columbus, OH

11/15 - 11/17 - IASB, Iowa Association of School Boards
 Iowa Events Center, Des Moines

Save the Dates (2018)

- NSBA - 4/7 - 4/8, San Antonio, TX
- IPTA - 7/16 - 7/18

CAN'T MAKE IT TO US.....WE'LL COME TO YOU!

Hoglund Bus Company offers Mobile Service in parts of Iowa. Contact **Tom Paulson** for details & scheduling.



Tom Paulson

T: 763.271.2962

E: mobileservice@hoglundbus.com

Title: J1939 Data Link Troubleshooting

iKNow Article: IKo800080

Applies to: All Models with 250k Baud Data Link (Black 9-Pin Diagnostic Connector); Overview information for 500k Baud Data Link

500k Baud Vehicle Architecture - Phase 1

This can be properly identified by looking in the components tab of the vehicle and looking for a GREEN 9-Pin connector and feature: 0508095 - ELECTRICAL SYSTEM ENHANCED VCM FUNCTIONS for VCM Enhanced Functions

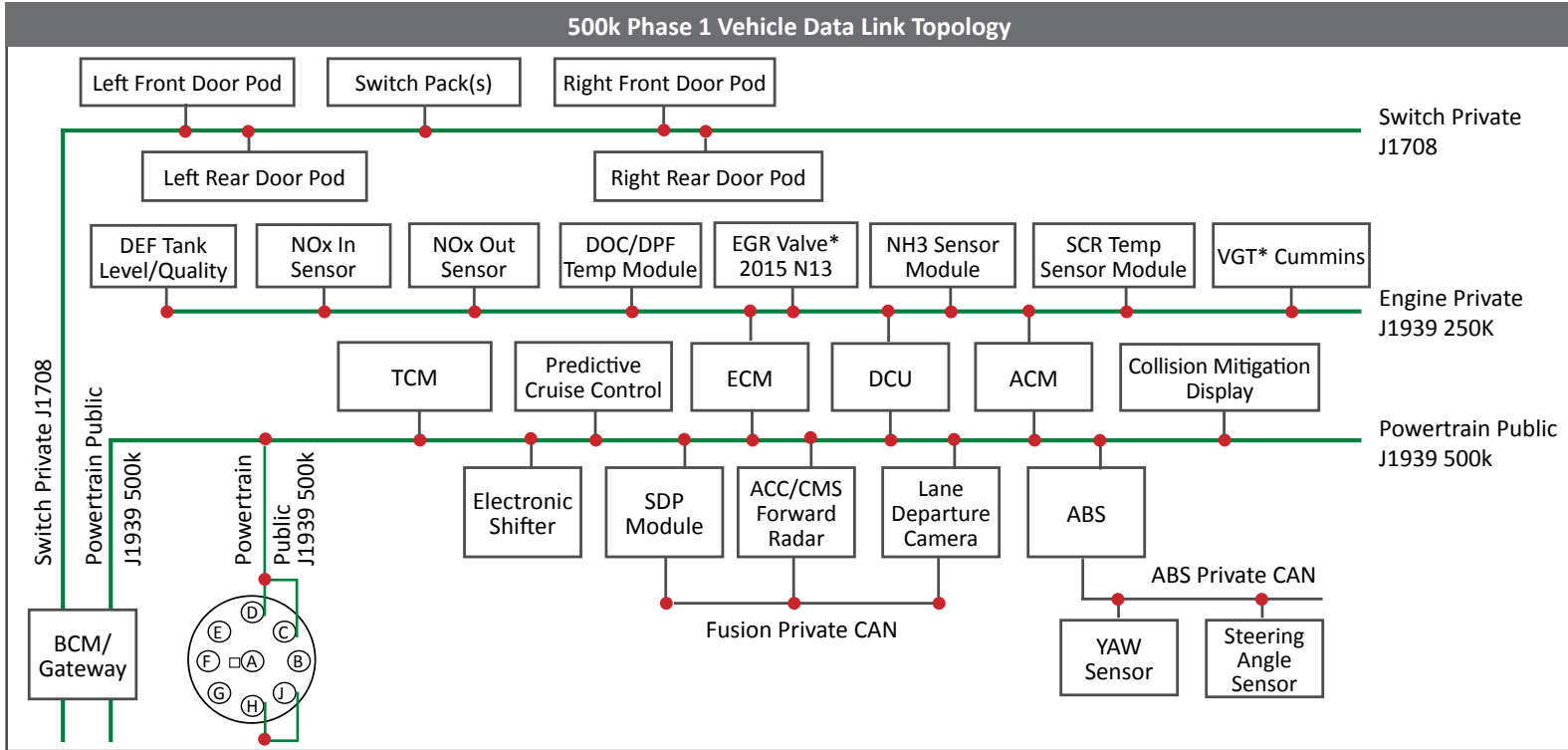

500k Baud Vehicle Architecture - Phase 2

This can be properly identified by looking in the components tab of the vehicle and looking for a GREEN 9-Pin connector and feature: 0508097 - ELEC SYS MUX COMMON ARCHITECTURE for Electrical Common Architecture System • This feature and vehicle architecture launched with the LT Model

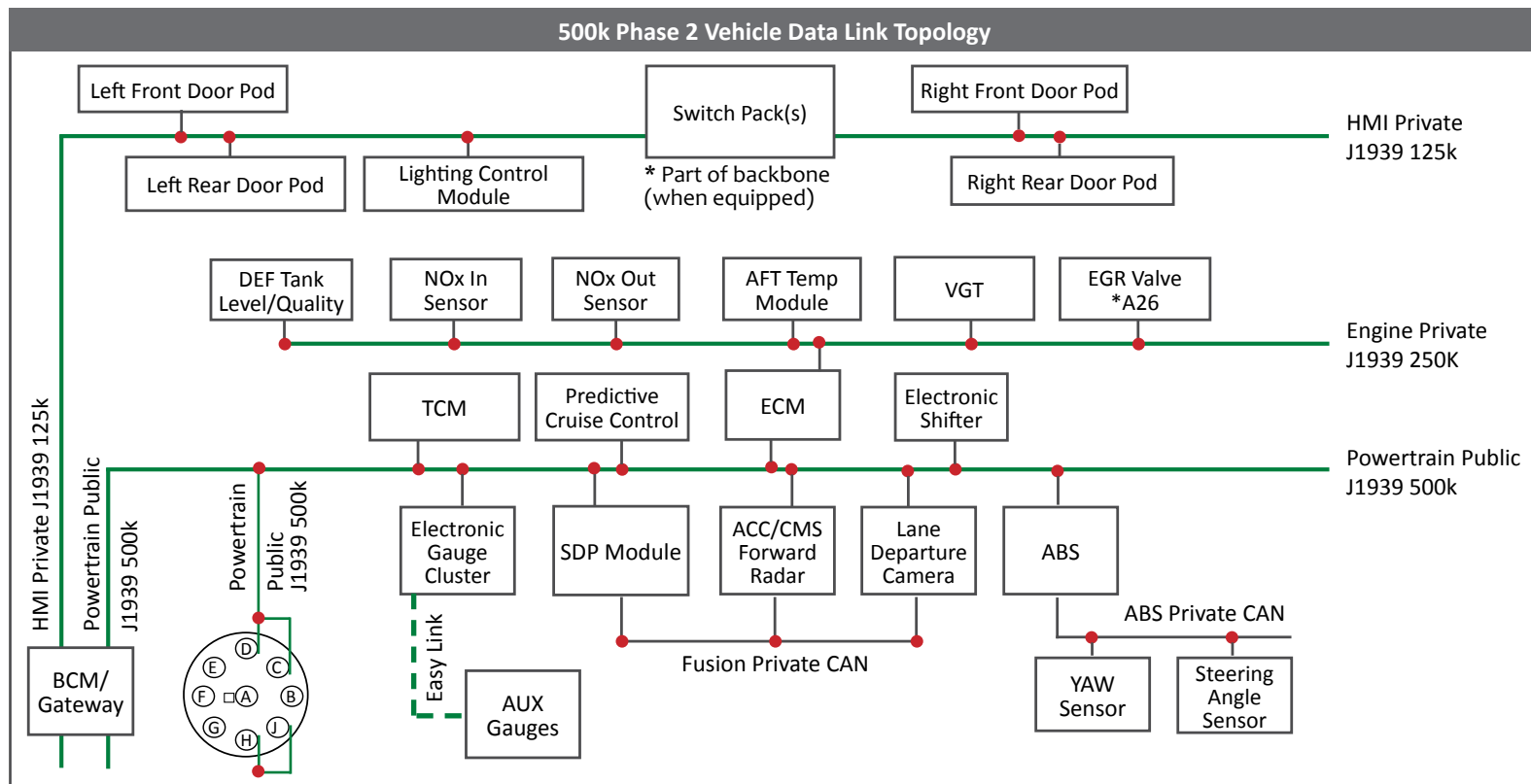

NEW BUS INVENTORY

PASS	YEAR	SPEC	MAKE	ENGINE	BRK
44+	2017	1705	IC - CE	ISB/240	A
65	2017	1706	IC - CE	ISB/240	A
65	2018	1802	IC - CE	Propane/270	A
65	2018	1805	IC - CE	ISB/240	A
65	2018	1813	IC - CE	ISB/250	A
77	2016	1615	IC - CE	MXDT/230	A
77	2017	1733	IC - CE	ISB/240	A
77	2018	1801	IC - CE	Propane/270	A
77	2018	1804	IC - CE	ISB/240	A

**Note: To view full list of inventory, visit www.hoglundbus.com*

USED BUS SPOTLIGHT



File: 22005Al Odometer: 38,397
 Year: 2013 Engine: MX7/220
 Make: IC-CE Fuel: Diesel
 Pass: 65 Brake: Hydraulic

• LOW MILES •



2017 COURSE CATALOG

- Hoglund Bus Company
 - OnCommand Connection
 - PSI Propane Training
 - MaxxFORCE 7, DT, 9, 10
 - CE Bus Program (Brakes, Electrical)
- IC Bus
 - 2007 Emissions Fundamentals
 - Navistar Safety
 - OnCommand Service & Parts Information
 - ServiceMaxx Introduction and Usage
 - MaxxFORCE DT, 9, 10 - Engine Overview: Brakes, Electrical, Door Adjustments
- Navistar
 - OnCommand Connection - Paid subscription available to purchase through Hoglund Bus, contact mnpartscoord@hoglundbus.com
- Meritor
 - Automatic Slack Adjuster
 - Foundation Brake



TECH SUPPORT: We invite you to contact our tech help-line with any technical or training questions.

Doug Yager: D: 763.271.2982 • C: 763.350.2597
 E: service@hoglundbus.com

WARRANTY SUPPORT: We invite you to contact our warranty dept. with any questions you might have.

Brian Tesmer:
 D: 763.271.2978 • E: brian.tesmer@hoglundbus.com

USED BUS INVENTORY

PASS	YEAR	MAKE	ENGINE	BRK	ODO
Large Conventional Buses 65 to 77 Passenger					
65	2015	IC	MXDT/230	A	42,148
65	2015	IC	ISB/220	H	44k
71	2014	IC	MXDT/245	A	47,434
65	2014	IC	MXDT/260	A	39,046
65	2014	IC	MXDT/245	A	54,037
65	2014	IC	MXDT/245	A	48,803
65	2014	IC	MXDT/230	H	30,620
65	2013	IC	MX7/220	A	40,483
65	2011	IC	MX7/215	A	84,229
65	2011	IC	MX7/215	A	56,262
65	2010	IC	MX7/215	A	73,225
77	2008	Frtl	Merc/210	A	95,059
71	2008	Frtl	CatC7/210	A	109,247
72	2004	IC	T444/210	A	120,503
71	2004	IC	T444/210	A	198,310
65	2003	Int	DT466/215	A	134,942
65	2002	Intl	T444/195	H	181,176
65	2002	TH	Cummins 5.9	A	177k

Transit Buses

84	1995	TH	Cummins 8.3L	A	237,041
----	------	----	--------------	---	---------

10 - 64 Passenger Buses

59	2012	IC	MX7/220	A	45,107
59	2008	TH	Merc/190	H	58,872
59	2000	Chev	Gas	H	227,316
59	1999	Intl	T444/190	H	143,461
59	1996	Chev	Gas	H	209,330
59	1994	Chev	6.0L	H	140,795

Special Needs & Lift Buses

45+/3WC	2017	IC	ISB/250	A	2,696
42+1	2008	Frtl	CatC7/220	A	104,196
46+	2007	BB	CatC7	A	132,846
33+	2005	IC	DT466/210	A	112,209
8+3	2004	Chev	Gas	H	120,928

**Note: To view full list of inventory, visit www.hoglundbus.com*

Service Special:

Fuel Tank Cleaning \$89.99

Return Service Requested

PARTS SPECIALS

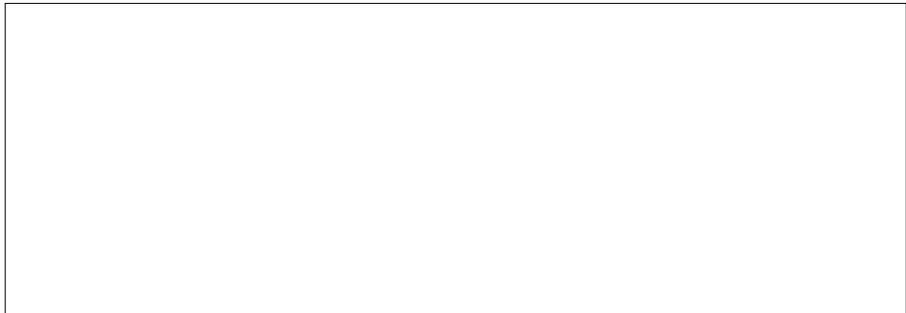

Weldon Supplemental Warning Light

\$349.⁹⁸ ea.



Part #: W3200-00-11

The supplemental warning light provides districts with extra safety for children. The supplemental LED warning light is placed at bumper level on the bus to provide an attention demanding signal that is more perceptible to a distracted motorist than the standard 8 lamp system alone.

800.866.3104

Stainless Steel Light Sale



p/n: W1080S110010 - Warning Light **\$14.⁶⁰ ea.**



p/n: W1080S110020 - Warning Light **\$14.⁶⁰ ea.**



p/n: W1010S112020 - Tail 2 wire amber **\$15.⁹⁵ ea.**



p/n: W1010S112010 - Tail 2 wire red **\$15.⁹⁵ ea.**

p/n: W1080S110610 - Warning Light, Halogen Red **\$22.⁹⁹ ea.**

p/n: W1080S110620 - Warning Light, Halogen Amber **\$22.⁹⁹ ea.**

Wiper Blade Sale!



ANCO9122
\$4.⁷⁹ ea.

ANCO9124
\$4.⁷⁹ ea.



FLTP22
\$4.⁴¹ ea.

FLTP24
\$4.⁴¹ ea.

Evacuation Blanket with nylon case



p/n: K604-058 **\$73.⁵⁶ ea.**

Fire Blanket with plastic case



p/n: K340-102 **\$73.⁵⁶ ea.**

Mirror Knob Kit - p/n: 6X30KB

Mirror knob kit allows drivers to adjust their 6 x 30 or 10 x 30 mirror before route **\$6.⁸⁷ ea.**

Stretch your parts dollars with these special offers!

Our Parts Department carries an extensive inventory of "All Makes" products and can supply everything needed to keep your vehicles running smoothly.