



NOVEMBER 2017

School Bus Flyer



Beginning January 2018, Hoglund Bus Co. will be going digital. We will not be printing our monthly School Bus Flyer. If you have not signed up for our e-newsletter yet, email Melissa at

marketing@hoglundbus.com to be added. We will still have the same informative content plus more industry news at your fingertip.

INSIDE THIS ISSUE:

- New & Used Inventory
Parts Specials
Service Information
Service Special

School Bus Sales Team

Marc Steele (Northern IA)

C: 641.512.3854

E: marcsteele@hoglundbus.com

Brian Glenney (Used Inventory Manager)

C: 641.751.4365

E: brianglenney@hoglundbus.com

Danny Thede (Southern IA)

C: 641.750.6428

E: danny.thede@hoglundbus.com

Parts Sales

Al Lucas

C: 641.750.8332

E: al.lucas@hoglundbus.com

DIRECT LINES:

Sales: 800.866.3105

Parts: 800.866.3104

Service: 877.752.4733

Tech Line: 763.271.2982

Warranty: 763.271.2978



www.hoglundbus.com

OnCommand

Empower Your Fleet Operations With More Visibility Than Ever Before

OnCommand™ Connection is the industry's first and only open architecture remote diagnostic system for fleets of all makes and models of vehicles. Use OnCommand™ Connection to proactively identify potential problems, improve vehicle uptime, control maintenance and lower repair costs.

Features & Benefits



Reduce en-route events by proactively scheduling maintenance and repair



Map tools that plot truck locations, nearest dealers, hotels and local towing providers



Generate real-time comprehensive vehicle health reports



Understand fault codes quickly and easily with descriptions in plain English



Gain more insight with fault code action plans that provide severity information & recommend solutions

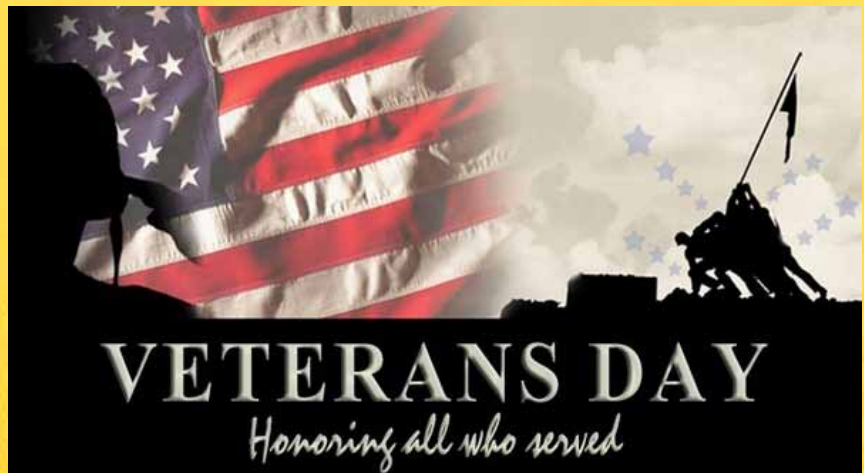

HOLIDAY HOURS

We will be closed Thursday, November 23rd

Applies To: Hydraulic Brake system equipped with 04GBJ Park Brake

Customer Concerns: Unit will not operate in reverse due to parking brake lock-up. Tech/Driver may find heat indications on park brake drum. Driver may experience “shuttering” from rear of vehicle while driving. Special Tool/Software: Vernier Caliper (obtain locally).

Service Parts Information: All quantities are 1

Kit Description	Part Number	Kit Description	Part Number	Kit Description	Part Number	Kit Description	Part Number
KIT SHOE AND LINING VERSION 2	2605826C91	KIT BRAKE SPRING	2605828C91	KIT ADJUSTER HARDWARE	2605830C91	DRUM, BRAKE DLM	3543437C1
KIT PARK BRAKE LEVER CAM PLATE SCREW	2605827C91	CABLE, PARKING BRAKE ADJUSTER	2605829C91	KIT SHOE HOLD DOWN BRACKET	2605831C91	CLAMP RUBBER CUSHIONED	3564290C1

DIAGNOSTIC STEPS: **WARNING:** To prevent unexpected movement of the vehicle and possible serious personal injury or death, park the vehicle on a flat, level surface, set the parking brake, turn the engine off and chock the wheels to prevent vehicle from moving in both directions. **WARNING:** To prevent property damage, personal injury and / or death, parking brake front cable must have 1.50 inches (38 mm) or more of thread engagement in the adjustment turnbuckle.

Step 1: Release park brake, remove drum and inspect for heat damage to drum or linings. Also inspect adjustment cable for damage. See fig. 1 and 2

Step 2: If any damage is present, replace drum and shoes along with adjustment cable. Make certain Adjustment cable is installed behind the Cam Plate. See figure 4. **Note:** If Starwheel free spins adjustment cable needs to be replaced.

Service Procedure:

Note: Follow all steps below to adjust driveline parking brake after inspection and replacement of parking brake components.

Adjustment With Drum OFF- Primary Procedure:

1. Use a 12 inch caliper, or inside micrometer, to measure the inside diameter of the drum. Subtract 0.025 inches from the drum inside diameter measurement. Set the measurement caliper to this value, and lock the set screw.
2. Rotate the axle input flange yoke as necessary to provide clearance for the measurement caliper.
3. Place the pre-adjusted caliper over the shoes at the center of the shoes.
4. To adjust brake, rotate the starwheel until the shoes touch the measurement caliper jaws. It is necessary to disengage the adjuster lever away from the starwheel.

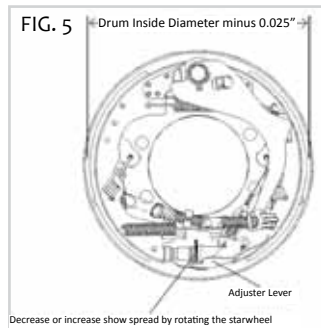
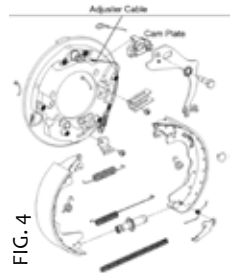

Adjustment with Drum Installed - Alternate Procedure

1. With the engine off, the battery disconnected, and the tires blocked to prevent vehicle movement, place transmission in neutral and fully release the parking brake. It will be necessary to raise the rear wheels off the ground, in order to allow rotation of the drum. Support the vehicle with suitable floor stands
2. Insert the adjuster lever tool or a thin flat bladed screw driver through the adjusting slot in the backplate and push on the adjuster lever to disengage it from the adjuster starwheel. Insert a brake adjusting tool (or flathead screwdriver) through the adjusting slot and move the starwheel teeth downward to expand the brake shoes outward. Continue expanding the shoes until the drum can not be rotated by hand.
3. Now adjust the starwheel teeth upward to retract the shoes until the drum just begins to rotate freely by hand (without drag from the shoes).

Parking Brake Cable Overview

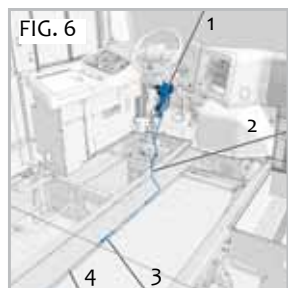

When the parking brake assembly pedal is depressed tension is applied through the front cable, adjustment turnbuckle, intermediate cable and rear cable. Cable tension is transferred forcing the brake shoes against the parking brake drum to prevent vehicle movement.

- Fig. 6
1. Parking brake assembly
 2. Front Cable
 3. Adjustment turnbuckle
 4. Intermediate cable

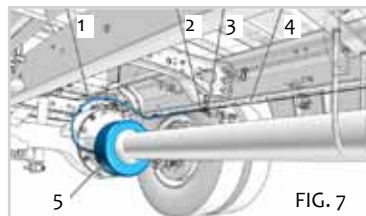

- Fig. 7:
1. Rear cable
 2. Cable spring assembly
 3. Rear cable mounting support bracket
 4. Intermediate cable
 5. Parking brake drum

Remove Park Brake Pedal Spring Damper

1. Before cable adjustment park brake pedal damper will need to be removed and discarded. Refer to figure 8.



2. Using a small screw driver with a flat blade lift the retaining clip slightly on the top of the ball socket and then pull the gas spring off the ball stud. Refer to fig. 9

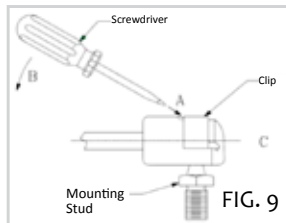

Parking Brake Cable Alignment

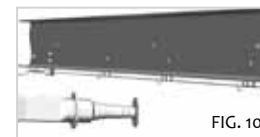

1. If vehicle was built before 10/12/2017, replace cushioned clamps with the larger 5/8" clamp specified in the parts section of this document. Make

Certain extensions and clamps on intermediate cable are aligned and not touching park brake cable. This will ensure that park brake cable has no restrictions to fully release and apply. Refer to fig. 10

NEW BUS INVENTORY

PASS	YEAR	SPEC	MAKE	ENGINE	BRK
44+	2017	1705	IC - CE	ISB/240	A
65	2017	1706	IC - CE	ISB/240	A
65	2018	1802	IC - CE	Propane/270	A
65	2018	1805	IC - CE	ISB/240	A
65	2018	1855	IC - CE	ISB/240	H
77	2016	1615	IC - CE	MXDT/230	A
77	2017	1733	IC - CE	ISB/240	A
77	2018	1801	IC - CE	Propane/270	A
77	2018	1804	IC - CE	ISB/240	A

*Note: To view full list of inventory, visit www.hoglundbus.com

CAN'T MAKE IT TO US....WE'LL COME TO YOU!

Hoglund Bus Company offers Mobile Service in parts of Iowa. Contact **Tom Paulson** for details & scheduling.



Tom Paulson

T: 763.271.2962

E: mobileservice@hoglundbus.com

USED BUS SPOTLIGHT • LOW MILES • LOW PRICE •



File: 22005Al Odometer: **38,397**
 Year: 2013 Engine: MX7/220
 Make: IC-CE Fuel: D
 Pass: 65 Brake: Hydraulic

\$41,000.00

Rear Cable Support Bracket/Cable Spring Assembly Alignment



FIG. 11

1. Make certain bracket and cable spring assembly are at a 90 degree (straight up and down). This will ensure spring assembly does not come in contact with frame upon park brake release or apply. Please refer to figure 11.

2. If not aligned please loosen two bolts, adjust and re-tourqe bolts to 41- 50 ft lbs (56-68 nm).

Parking Brake Cable Adjustment

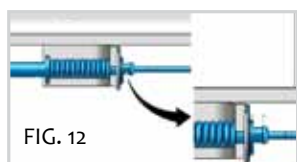

FIG. 12

NOTE: NEW SPEC FOR MEASUREMENT STARTS AT 11mm MAX 14mm. 1. Release parking brake loosen jam nut to adjust turnbucke item number 3 in figure 6. 2. Apply and release parking brake all the

way to the floor (bottomed out) Perform this step 3 times before continuing to step 3. 3. Fully apply park brake, using Vernier calipers measure critical distance in figure 12. Spec is 11mm -14mm. 4. After correct cable tension adjustment, lock jam nut and proceed to Park Brake Operation section of this document.

USED BUS INVENTORY

PASS	YEAR	MAKE	ENGINE	BRK	ODO
Large Conventional Buses 65 to 77 Passenger					
65	2015	IC	MXDT/230	A	42,148
65	2015	IC	ISB/240	A	42,922
65	2015	IC	MXDT/230	A	23,604
65	2014	IC	MXDT/260	A	39,046
65	2013	IC	MX7/220	A	40,483
65	2011	IC	MX7/215	A	84,229
65	2007	IC	DT466/220	A	145,643
65	2003	TH	Cum. 5.9	A	181,761
65	2001	Intl	DT466/195	H	209,012
65	2000	TH	Cum. 5.9	A	172,078
65	1999	Frtl	Cummins 5.9L/195	H	186,075
65	1996	Int	T444/190	H	168,818
71	2014	IC	MXDT/245	A	47,434
71	2008	Frtl	CatC7/210	A	109,247
72	2004	IC	T444/210	A	120,503
77	2015	IC	MXDT/230	A	31,027
77	2008	Frtl	Merc/210	A	95,059
Transit Buses					
83	2004	TH	Cum. 5.9	A	21,414+
84	2000	Frtl	Cat3126	A	172k
84	1995	TH	Cummins 8.3L	A	237,041
10 - 64 Passenger Buses					
22	2004	Chev	6.0L	H	148,206
53	2012	IC	MX7/220	H	42,234
59	2008	TH	Merc/190	H	58,872
59	2007	BB	Cat C7	A	135,124
Special Needs & Lift Buses					
33+	2005	IC	DT466/210	A	112,209
42+1	2008	Frtl	CatC7/220	A	104,196
44+	2007	IC	DT466/220	A	104,957
46+	2007	BB	CatC7	A	132,846
8+3	2004	Chev	Gas	H	120,928

* Information deemed reliable but not guaranteed

Parking Brake Operation

Upon parking brake release make certain pedal is fully releasing. With Parking brake applied Place Vehicle into Drive and Reverse rev engine to 1500 RPM and make certain vehicle does not pull away. If vehicle pulls away the parking brake cable adjustment will need to be set at the higher end of the spec. Release parking brake and drive forward and reverse making sure no brake drag is present. If any concerns arise while performing operational checks run through brake adjustment steps again and make certain no steps were missed. After all checks are complete return vehicle into service.

Return Service Requested

PARTS SPECIALS

“CLOSEOUT PRICE”



Power Service Diesel 911
 Restores the flow of diesel fuel to an engine caused by gelled fuel or frozen fuel-filters.
 Part Number: PSP8025

\$4.98 ea.



Wiper Shakers
 Keeps wiper blades clear of snow and ice.
 Part Number: SKR002

\$69.99 each



Commercial Grade Extension Cords
 12/3 - 2 pack 50 foot lighted extension cords
 Part Number: 962804

\$48.98 each



Frost Scraper/Snow Brush
 30” extends to 48”

\$8.99 each

IC Tempered Door Glass
 Buy 10 - Get one FREE!

\$99.99 ea.

Stretch your parts dollars with these special offers!

800.866.3104



ANCO WINTER BLADES

ANCO3020 and ANCO3022 \$4.31 each

ANCO3024 \$4.66 each

WINTERFRONT



We are all about warm. Why settle for an Arizona Winterfront? We offer full Winterfronts for IC and Thomas buses!

Fresh Air Intake Covers for all IC and Bluebird buses!

CALL FOR PRICING

Our Parts Department carries an extensive inventory of “All Makes” products and can supply everything needed to keep your vehicles running smoothly.